

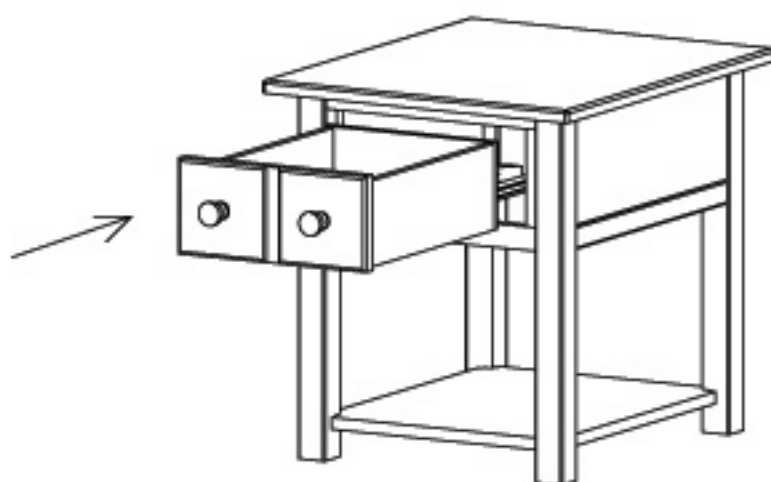

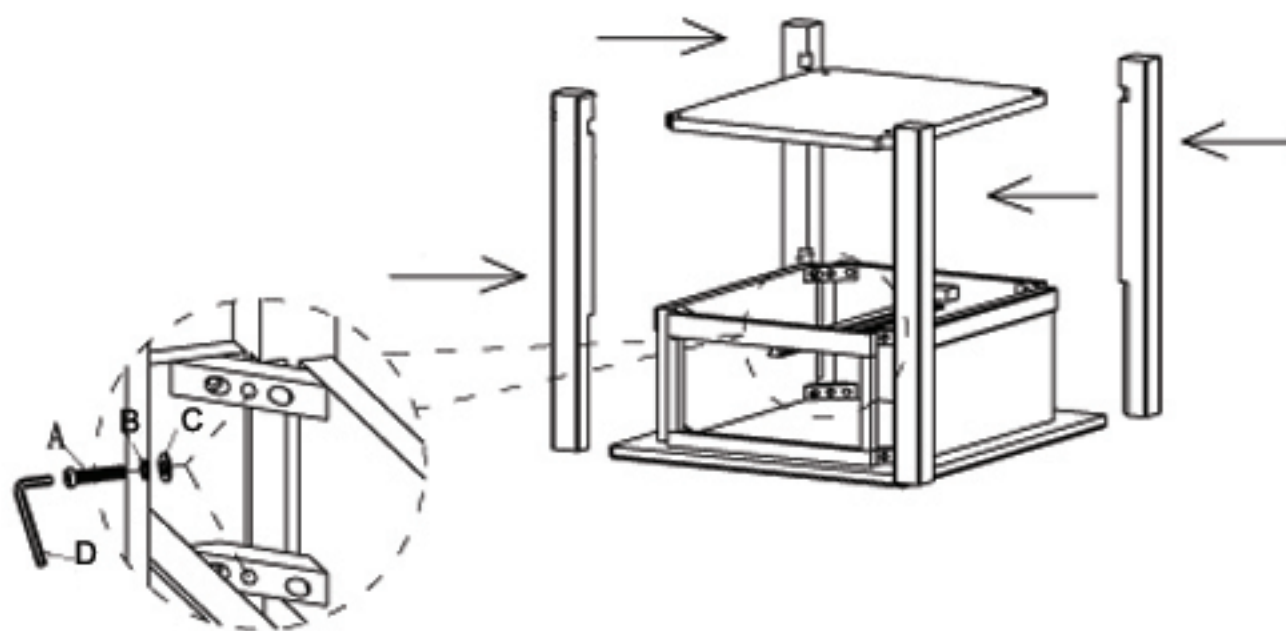

# ASSEMBLY INSTRUCTION

ITEM NO: #2609-22 & #2709-22

RECT END TABLE



DO NOT TIGHTEN SCREWS  
UNTIL COMPLETELY ASSEMBLED

Item	Sketch	Description	Qty
A		Bolt $\varnothing 1/4 \times 2"$	8PCS
B		Spring washer $\varnothing 1/4 \times 11\text{mm}$	8PCS
C		Flat washer $\varnothing 1/4 \times 16\text{mm}$	8PCS
D		Wrench 4mm	1PC