







Assembly Instruction

CH104W24FKDW
NAPOLEON COUNTER HEIGHT CHAIR

HARDWARE PARTS:

						
Pan Head Screw 6 pcs	(Short) JCBC Bolt 2 pcs	(Long) JCBC Bolt 8 pcs	Lock Washer 10 pcs	Flat Washer 10 pcs	Allen Key 1 pce	Glue 1 pce

ASSEMBLY:

- Position the chair back on a soft surface such as a carpet. Place the box system assembly (Hardseat is pre-attached to the seat frame in assembly) on to the middle rail of the chair back with the dowel fully inserted into the pre-drilled hole.
 - Insert **JCBC Bolt (Long)** through a **Lock Washer** and a **Flat Washer** into the pre-drilled holes on the apron frame at rear corners.
 - Insert the **JCBC Bolt (Short)** through a **Lock Washer** and a **Flat Washer** into the pre-drilled holes on the apron frame at rear rail.
- Apply **Glue** to all the pre-drilled holes before attaching all stretchers. Insert each side stretcher into pre-drilled holes on both of the rear legs, make sure that screw holes on the stretcher are facing down. Insert the front stretcher into the pre-drilled holes on the front legs. Place the assembled front legs to corner block of the frame, and insert side stretcher into the legs.
 - Insert the **JCBC Bolt (Long)** through a **Lock Washer**, a **Flat Washer** and the pre-drilled holes of corner block into the pre-drilled holes on the front leg, tighten the **JCBC Bolt** with **Allen Key** provided. But do not fully tighten the bolts yet.
 - Insert **Pan Head Screw** into front stretcher and side stretcher through the pre-drilled holes, tighten with screw driver. (Not Provided)

STEP 1

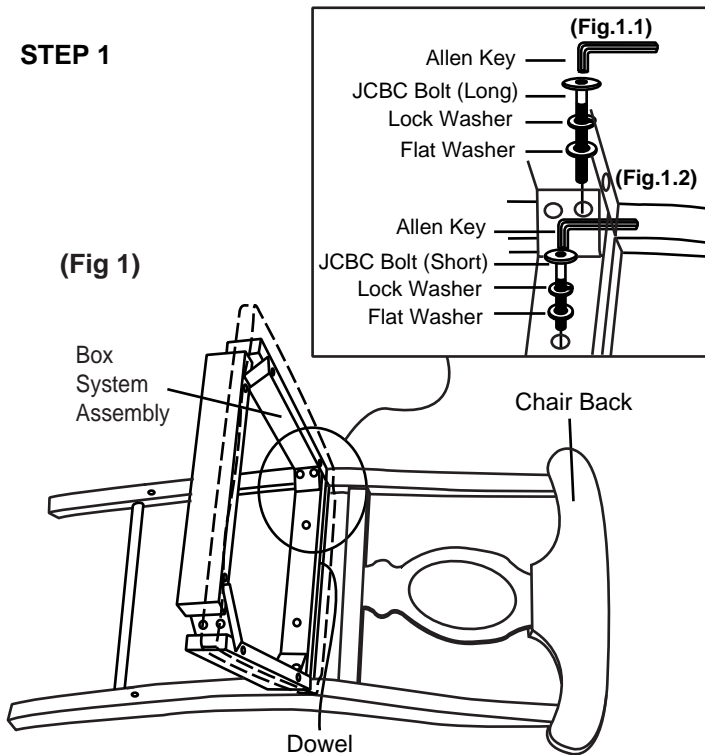

STEP 2

Apply Glue and insert stretcher with screw holes facing down.

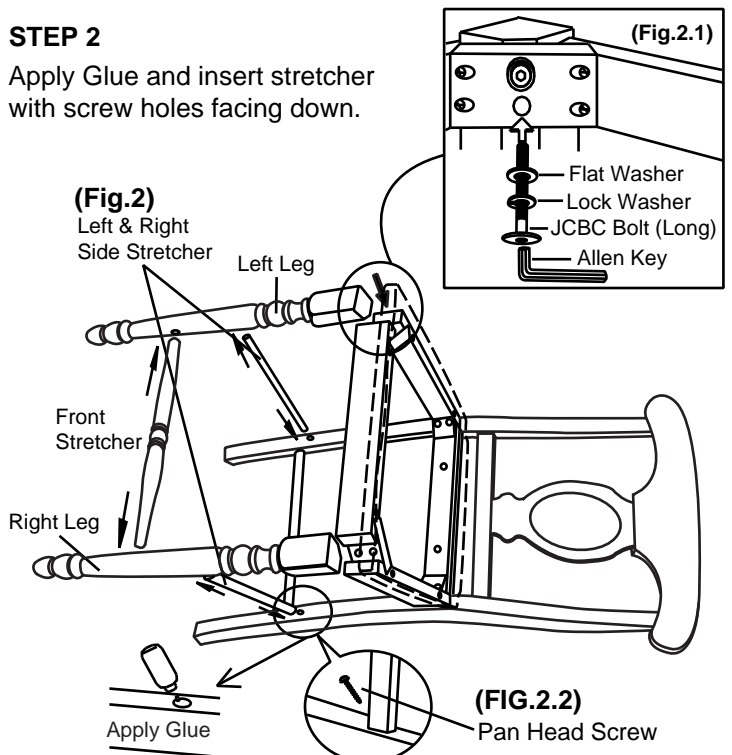

STEP 3

Turn the chair upright. Check its balance and tighten all screws and bolts to complete the assembly.

