







Assembly Instruction

SH105W01E2NM / SH105F01E2NM
PARKWOOD SPLATBACK SIDE CHAIR

HARDWARE PARTS:

						
Pan Head Screw 4 pcs	(Short) JCBC Bolt 2 pcs	(Long) JCBC Bolt 8 pcs	Lock Washer 10 pcs	Flat Washer 10 pcs	Allen Key 1 pce	Glue 1 pce

ASSEMBLY:

1. Position the chair back on a soft surface such as a carpet. Place the chair apron frame on to the middle rail of the chair back with the dowel fully inserted into the pre-drilled holes. Make sure that the screw holes on the apron frame are facing down.
 - 1.1. Insert JCBC Bolt (Long) through a Lock Washer and a Flat Washer into the pre-drilled holes on the apron frame at rear corners.
 - 1.2. Insert the JCBC Bolt (Short) through a Lock Washer and a Flat Washer into the pre-drilled holes on the apron frame at rear rail.
2. Apply Glue to all the pre-drilled holes before attaching all stretcher. Insert each side stretcher into pre-drilled holes on both of the rear legs, make sure that screw holes on the stretcher are facing down. Place the front legs to corner block of the frame, and insert side stretcher into legs.
 - 2.1. Insert the JCBC Bolt (Long) through a Lock Washer, a Flat Washer and the pre-drilled holes of corner block into the pre-drilled holes on the front leg, use the provided Allen Key but do not fully tighten the bolts yet.
 - 2.2. Insert Pan Head Screw into side stretcher through the pre-drilled holes, tighten with screw-driver (Not Provided).

(STEP 1)

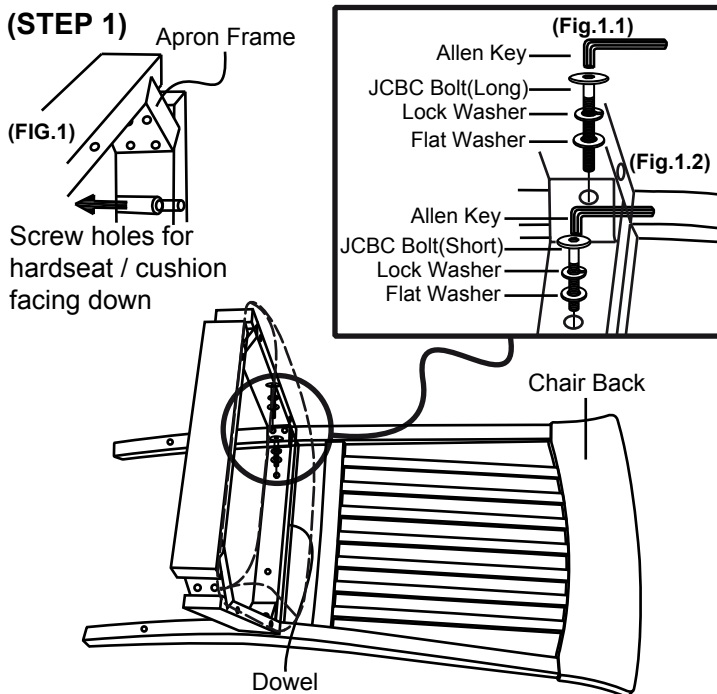

(STEP 2)

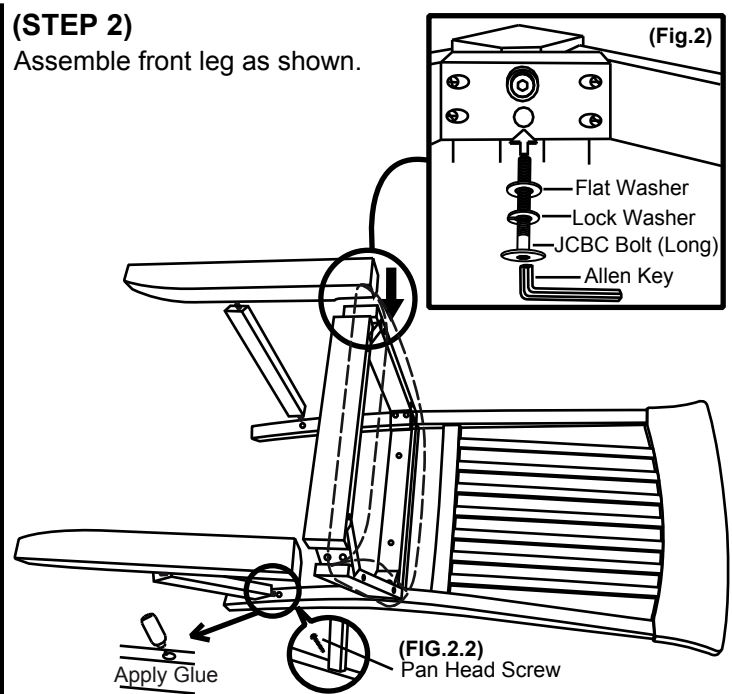

(STEP 3)

Turn the chair upright. Check its balance and tighten all screws and bolts to complete the assembly.

